

Nano Coax Vibration and Mechanical Shock Test

July 11, 2018

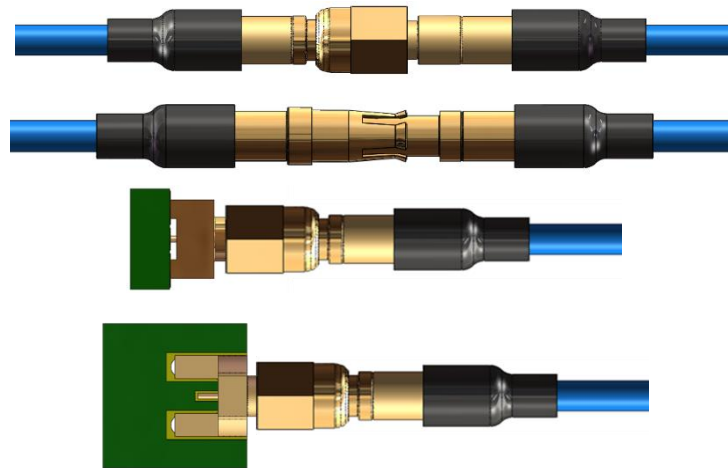

1. Product Description

- 1.1 **Assembly P/N:** A75593-001 mated to A75590-001; A75593-001 mated to A75591-001; A75593-001 mated to A75592-001; A75589-001 mated to A75588-001
- 1.2 **Connector Descriptions:** Nano Coax Board Mount and Cabled mates

2. Test Description¹

- 2.1 **Purpose:** Perform vibration and mechanical shock testing on mated connectors described above.
- 2.2 **Method:** Follow test plan as follows:
 - Sine Vibration
 - Contact Resistance
 - Mechanical Shock
 - Contact Resistance

3. Test Summary

- 3.1 **Sine Vibration:** Evaluation of electrical stability when exposed to vibratory environment.
- 3.2 **Contact Resistance:** Evaluation of contact resistance characteristics (before and after critical tests)
- 3.3 **Mechanical Shock:** Evaluation of electrical stability when subjecting to shock.

¹ Full report available upon request.

4. Test Results

Test	Requirement	A75593-001/ A75590-001	A75593-001/ A75591-001	A75593-001/ A75592-001	A75588-001/ A75589-001
Sine Vibration	No Damage	PASSED	PASSED	PASSED	PASSED
	1.0 microsecond	PASSED	PASSED	PASSED	PASSED
Contact Resistance	Record	99.3 mV MAX	62.8 mV MAX	61.1 mV MAX	84.0 mV MAX
Mechanical Shock	No Damage	PASSED	PASSED	PASSED	PASSED
Contact Resistance	1.0 microsecond	PASSED	PASSED	PASSED	PASSED
	Record	100.8 mV MAX	64.2 mV MAX	54.3 mV MAX	81.5 mV MAX

5. Test Procedures

5.1 Sine Vibration: Performed in accordance with MIL-PRF-39012 and MIL-STD-202, Method 204, Test Condition B. Test conditions:

- Frequency = 10 to 2000 to 10 Hz
- Amplitude = 0.06" da or 15 G's
- Duration = 4.0 hrs/axis, 3 axes total
- Test Current = 100 mA
- Sweep time = 20.0 minutes

5.2 Contact Resistance: Performed in accordance with MIL-PRF-29012, Paragraph 4.6.13. The points of application were in accordance with Figure #2 of MIL-PRF-39012 as shown below:

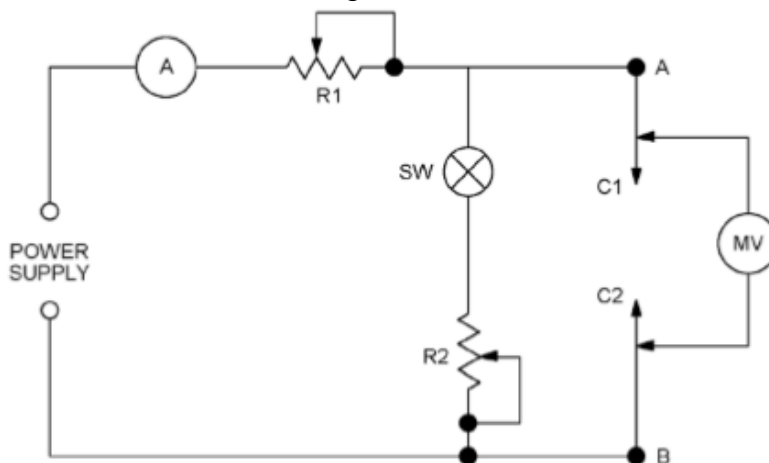

5.3 Mechanical Shock: Performed in accordance with MIL-PRF-39012 and MIL-STD-202, Method 213. Test conditions:

- Peak Value = 100 G
- Duration = 6 milliseconds
- Wave Form = Sawtooth
- Velocity = 9.7 feet per second
- No. of shocks = 3 shock per direction, 3 axis (18 Total)

6. Test Equipment

<u>EQUIPMENT LIST</u>								
ID#	Next Cal	Last Cal	Equipment Name	Manufacturer	Model #	Serial #	Accuracy	Freq. Cal
30	4/13/2018	4/13/2017	Discontinuity Monitor	Assoc. Test Lab	DM-600-01	382-1	See Cal Cert	12 mon
34	N/A	N/A	Shock Machine	Avco	SM110-3	1047	N/A	Ea Test
117	N/A	N/A	Digitizing Scope	Hewlett Packard	54200	2445A 00127	N/A	N/A
196	6/22/2018	6/22/2017	Digital Multimeter	Hewlett Packard	3478A	2301A14520	See Cal Cert	12 mon
282	N/A	N/A	Vibration Shaker Table	Ling Dynamics	V-730	163	N/A	N/A
553	3/20/2018	3/20/2017	12 channel Power Unit	PCB Piezotronics	483A	1303	See Cal Cert	12 mon
684	6/19/2018	6/19/2017	Accelerometer	PCB Piezotronics	353B04	47648	See Cal Cert.	12 mon
1010	N/A	N/A	Plotter	Hewlett Packard	7225B	2160A2293	N/A	N/A
1243	N/A	N/A	Computer	ARC Co.	P450	BU-001	N/A	N/A
1439	5/25/2018	5/25/2016	Programable DAC Unit	Hewlett Packard	35656B	3244A00342	See Cal Cert	24 mon
1474	N/A	N/A	Vib Pwr Amp	tira	A58312	003/06	N/A	N/A
1521	N/A	N/A	Accelerometer	PCB Piezotronics	353B04	118492	N/A	N/A
1561	N/A	N/A	DC Power Supply	B&K	BKPREC9110	4001121	See Spec	Ea Test
1623	N/A	N/A	Kit Contact Res	Contech Resarch	CRK-CR-01	001	N/A	Ea Test
1752	3/3/2018	3/3/2017	Digital Multimeter	Agilent	34401A	MY47054034	See Cal Cert	12 mon
1758	5/25/2018	5/25/2016	8 Chan Input Module	HP	35655A	2911A02026	N/A	24 mon
1793	N/A	N/A	Computer	Dell	Optiplex	CKWCPC1	N/A	N/A
1832	8/4/2017	8/4/2016	1usec Discontinuity Detector	Contech Research	CRL-364TP46-DET1	0001	See Cal Cert	12 mon
1869	9/7/2017	9/7/2016	NC/NO Discontinuity Detector	Contech Research	CRL-DET2	001	See Cal Cert	12 mon

TABLE 6-1: List of test equipment