

Single Row Micro Strip

PS1/PS2-H2 LAYOUT

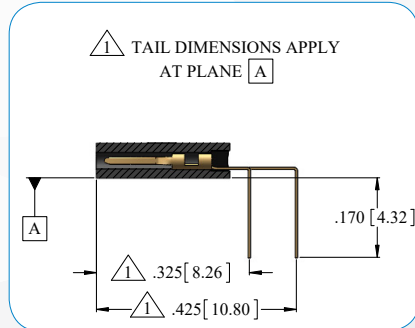
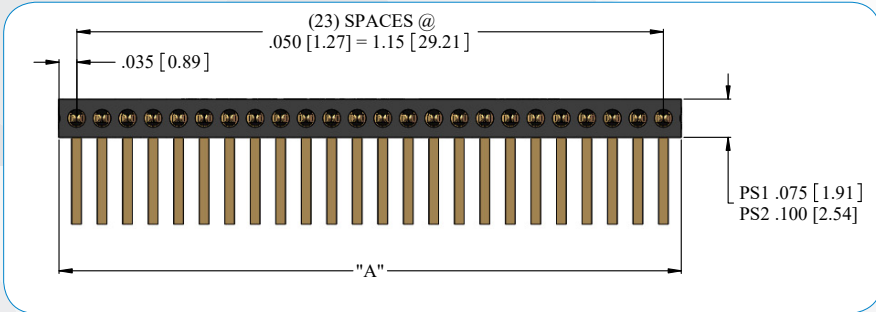
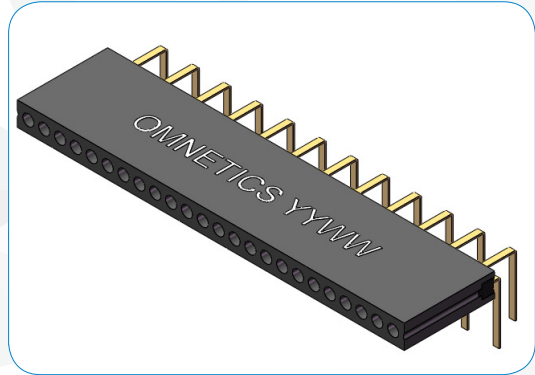
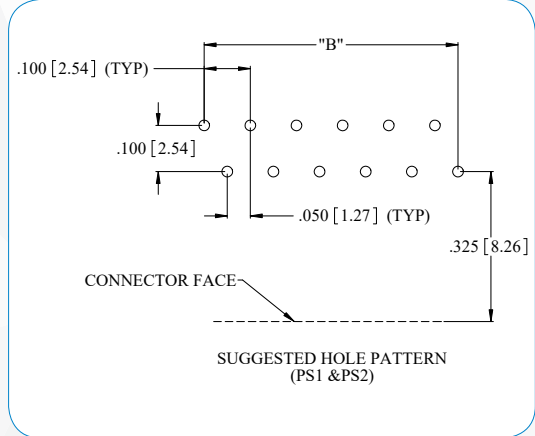
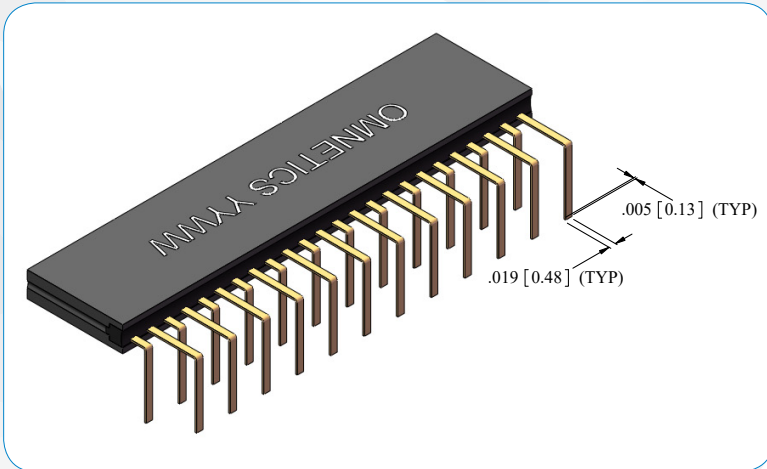

DIMENSIONS FOR "A"

To determine connector length "A":

Add the total number of contacts	_____
Add 1 contact cavity for each latch	_____
Add 1 contact cavity for each guide post hole	_____
Total contact cavities	_____
Multiply the number of contact cavities minus 1 by .050"	_____
Add .150" (3 contact cavities) for each mounting hole	_____
Add fixed end length	.070"
Total Length (Dimension A)	_____

Notes: Maximum length for PS1 @ .075" thick 2.42" (61.47) Maximum number of contact cavities is 48. Maximum length for PS2 @ .100" thick 3.02" (76.71) Number of contacts must be reduced to accommodate hardware and mounting holes. Default locations for guide post holes and latches may be changed by customer.

DIMENSIONS FOR "B"

To determine pad pattern layout length "B":

Multiply the number of contact cavities minus 1 by .050"	_____
If hardware features are within the contact area:	
Add .050" (1 contact cavity) for each latch	_____
Add .050" (1 contact cavity) for each guide post	_____
Add .150" (3 contact cavities) for each mounting hole	_____
Total Length (Dimension B)	_____

Notes: Maximum hole pattern layout length for PS1 is 2.35" (59.69). Maximum hole pattern layout length for PS2 is 2.95" (74.93). Add .100" from center of mounting hole to first hole (if the first contact cavity is used for a guide post or latch, .100" dimension must be adjusted).

Dimensions in [] are in Millimeters unless otherwise noted and are for reference only.

Single Row Micro Strip

SSB-H2 LAYOUT

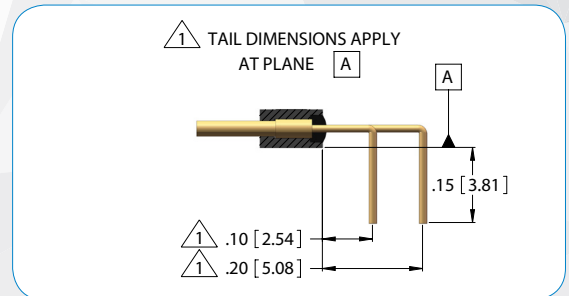
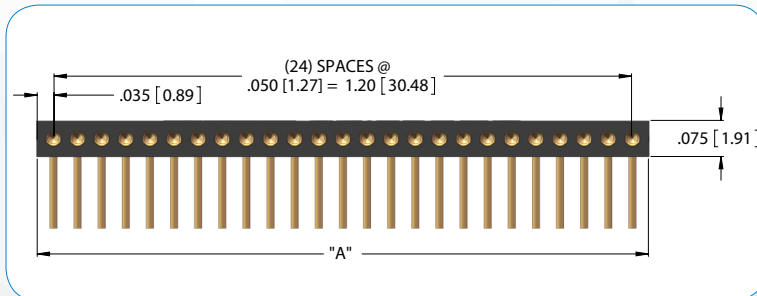
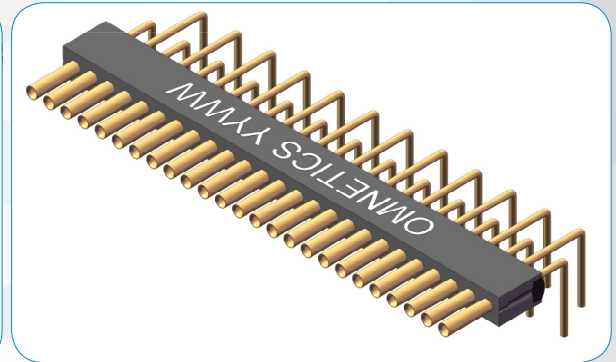
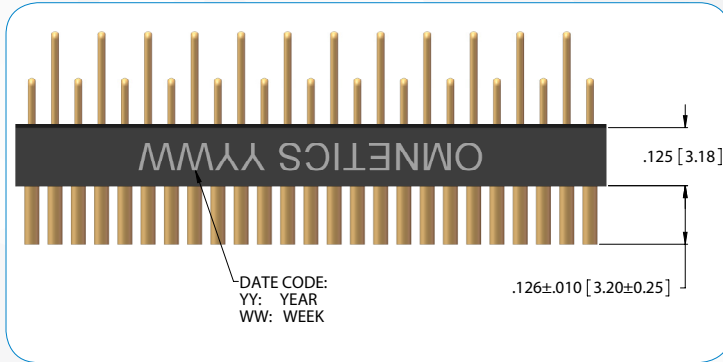
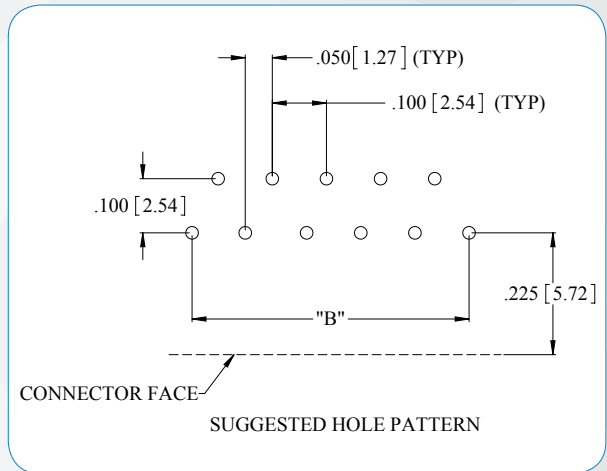
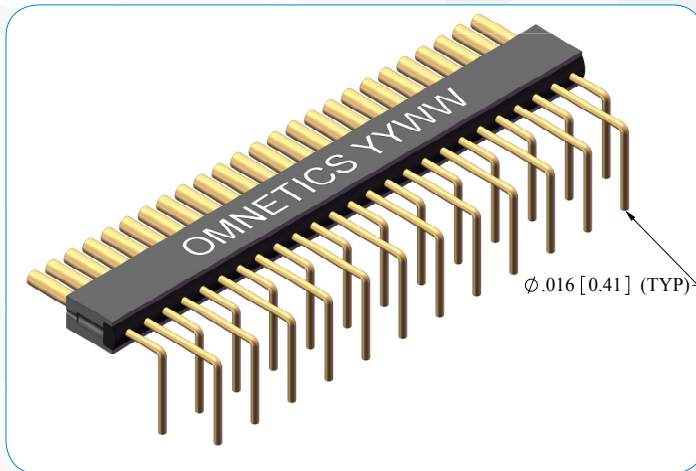

DIMENSIONS FOR "A"

To determine connector length "A":

Add the total number of contacts	_____
Add 1 contact cavity for each latch	_____
Add 1 contact cavity for each guide post	_____
Total contact cavities	_____
Multiply the number of contact cavities minus 1 by .050"	_____
Add .150" (3 contact cavities) for each mounting hole	_____
Add fixed end length	.070"
Total Length (Dimension A)	_____

Notes: Maximum length 2.42" (61.47). Maximum number of contact cavities is 48. Number of contacts must be reduced to accommodate hardware and mounting holes. Default locations for guide posts and latches may be changed by customer.

DIMENSIONS FOR "B"

To determine pad pattern layout length "B":

Multiply the number of contact cavities minus 1 by .050"	_____
If hardware features are within the contact area:	_____
Add .050" (1 contact cavity) for each latch	_____
Add .050" (1 contact cavity) for each guide post	_____
Add .150" (3 contact cavities) for each mounting hole	_____
Total Length (Dimension B)	_____

Notes: Maximum hole layout length 2.35" (59.69). Add .100" from center of mounting hole to first hole (if the first contact cavity is for a guide post or latch, .100" dimension must be adjusted).

Dimensions in [] are in Millimeters unless otherwise noted and are for reference only.