

HARDWARE & MISC

HARDWARE OPTION 00
- NO HARDWARE

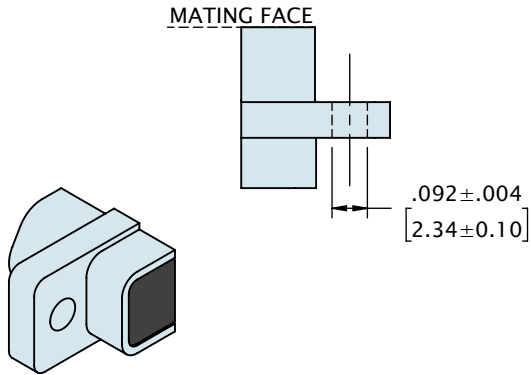

HARDWARE OPTION 01
- FIXED JACKPOST

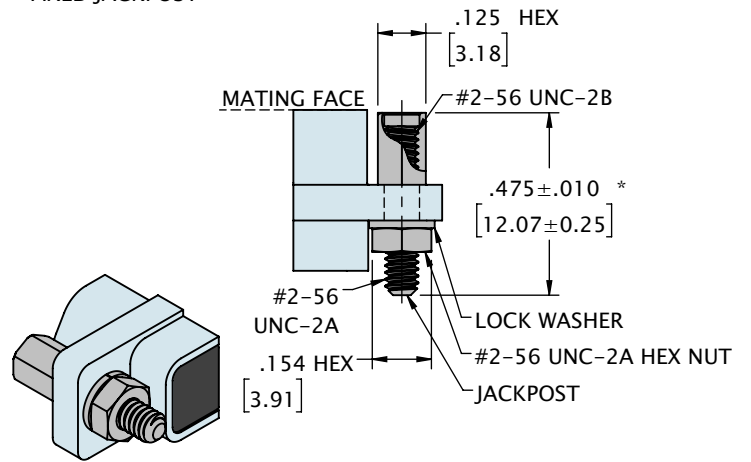

**FOR ALL TYPES EXCEPT DD AND H2. OVERALL LENGTH FOR STANDARD DD JACKPOST IS .560 [14.22] MAX AND .385 [9.78] MAX FOR H2

HARDWARE OPTION 02
- JACKSCREW, STANDARD LENGTH W/ HEX DRIVE

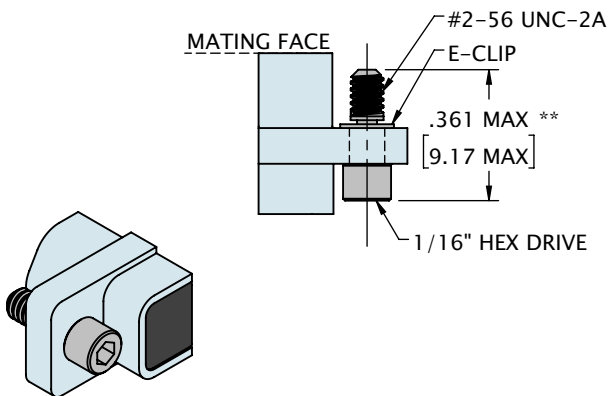

**FOR ALL TYPES EXCEPT HORIZONTAL SURFACE MOUNT (H0) OVERALL LENGTH FOR STANDARD H0 JACKSCREW IS .485 [12.32] MAX.

HARDWARE OPTION 03
- JACKSCREW, STANDARD LENGTH W/ SLOTTED DRIVE

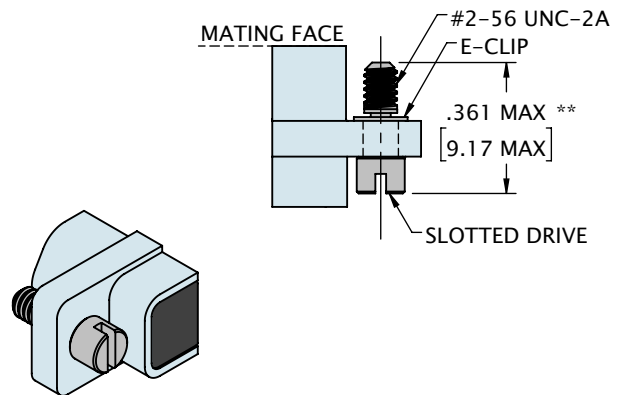

**FOR ALL TYPES EXCEPT HORIZONTAL SURFACE MOUNT (H0) OVERALL LENGTH FOR STANDARD H0 JACKSCREW IS .485 [12.32] MAX.

HARDWARE OPTION 04
- JACKSCREW, LONG LENGTH W/ HEX DRIVE

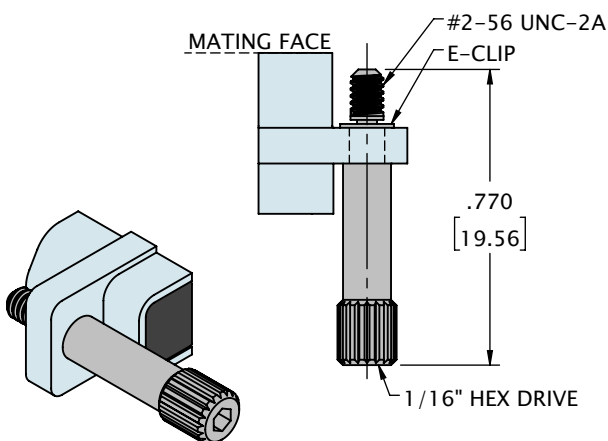

HARDWARE OPTION 05
- JACKSCREW, LONG LENGTH W/ SLOTTED DRIVE

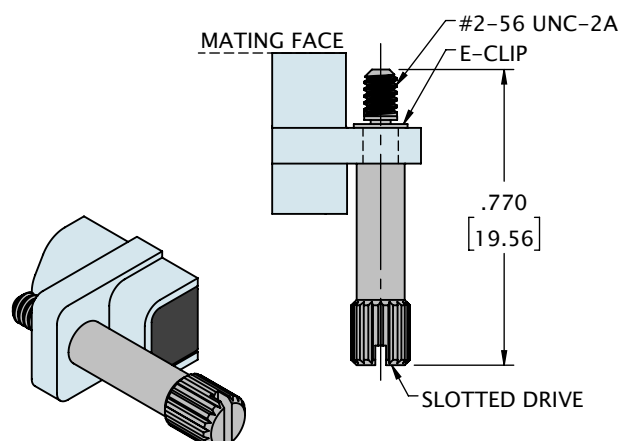

HARDWARE OPTION 06
- FLOAT MOUNT, FRONT MOUNTED

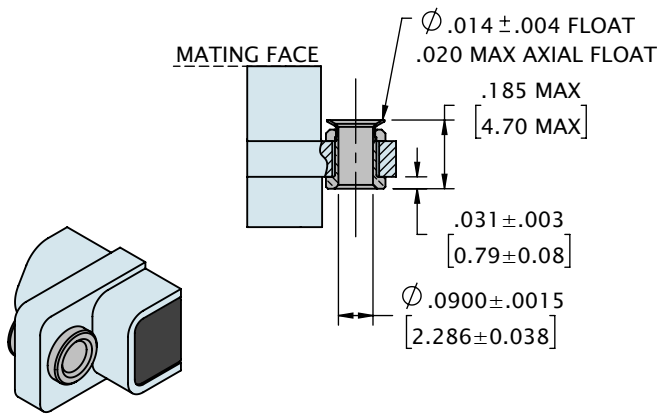

HARDWARE OPTION 07
- FLOAT MOUNT, REAR MOUNTED

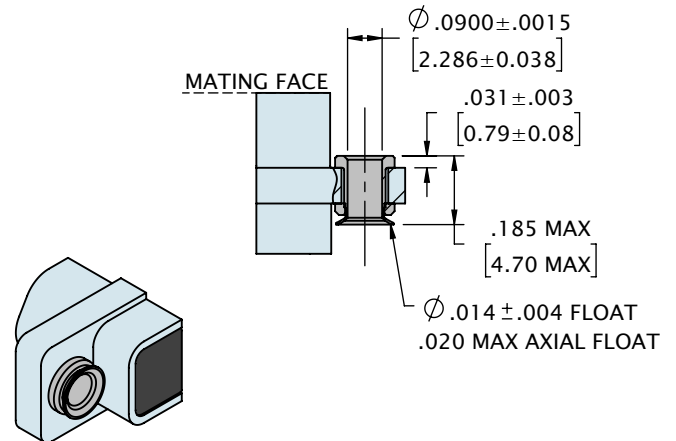

TO ORDER LOOSE HARDWARE SEPARATELY USE OMNETICS PART NUMBERS BELOW

JACKSCREW ASSEMBLY, #2-56,
STANDARD LENGTH WITH HEX DRIVE

OMNETICS PART #:
A97007-001

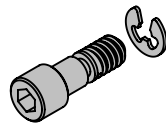

HARDWARE CODE:
02

JACKSCREW ASSEMBLY, #2-56,
STANDARD LENGTH WITH HEX DRIVE
FOR HORIZONTAL SURFACE MOUNT (H0)

OMNETICS PART #:
A97007-003

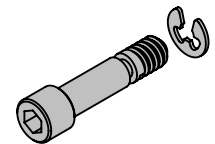

HARDWARE CODE:
02

JACKSCREW ASSEMBLY, #2-56,
STANDARD LENGTH WITH SLOTTED
DRIVE

OMNETICS PART #:
A97008-001

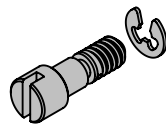

HARDWARE CODE:
03

JACKPOST ASSEMBLY, #2-56,
STANDARD

OMNETICS PART #:
A97009-001

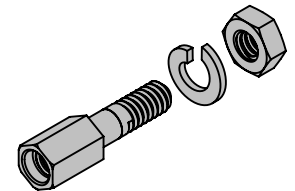

HARDWARE CODE:
01

JACKSCREW ASSEMBLY, #2-56, LONG
LENGTH WITH HEX DRIVE

OMNETICS PART #:
A97007-002

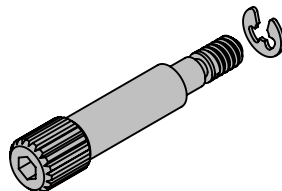

HARDWARE CODE:
04

JACKPOST ASSEMBLY, #2-56, EXTENDED
FOR STRAIGHT THRU-HOLE (DD)

OMNETICS PART #:
A97009-002

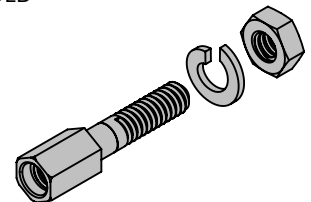

HARDWARE CODE:
01

JACKSCREW ASSEMBLY, #2-56, LONG
LENGTH WITH SLOTTED DRIVE

OMNETICS PART #:
A97008-002

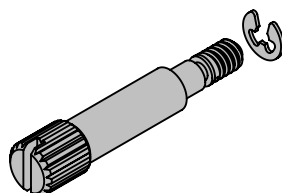

HARDWARE CODE:
05

JACKPOST ASSEMBLY, #2-56, SHORT
FOR RIGHT ANGLE THRU-HOLE (H2)

OMNETICS PART #:
A97009-003

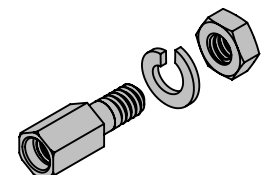

HARDWARE CODE:
01

FRONT PANEL MOUNT HARDWARE

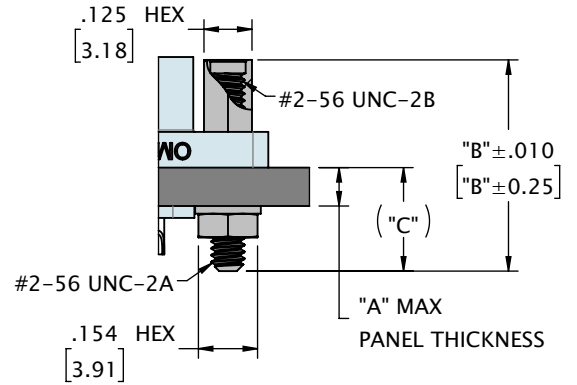
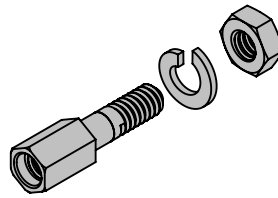
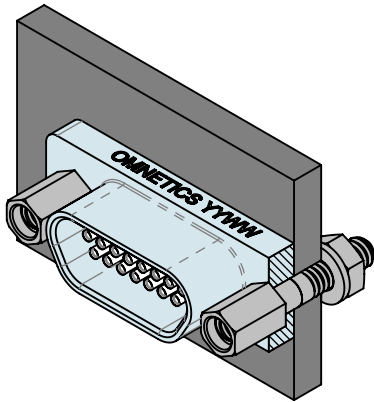

NOTE: EACH KIT INCLUDES TWO (2) JACKPOSTS, WASHERS AND NUTS. FOR USE WITH STANDARD WIRED (WD) OR SOLDERCUP (SS) MICRO-D CONNECTORS.

OMNETICS PART #	"A"	"B"	"C"
A97006-001	.05 [1.3]	.475 [12.07]	.195 [4.95]
A97006-002	.13 [3.3]	.550 [13.97]	.270 [6.86]

DIMENSIONS IN [] ARE IN MILLIMETERS AND ARE FOR REFERENCE ONLY

REAR PANEL MOUNT HARDWARE

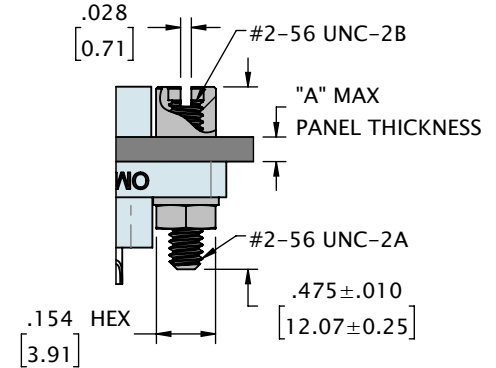
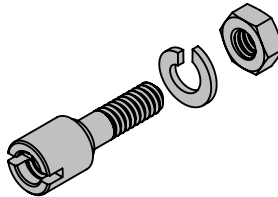
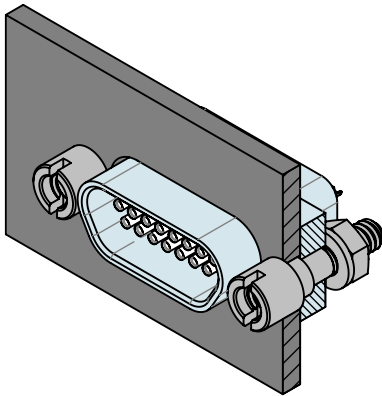

NOTE: EACH KIT INCLUDES TWO (2) JACKPOSTS, WASHERS AND NUTS. FOR USE WITH STANDARD WIRED (WD) OR SOLDERCUP (SS) MICRO-D CONNECTORS.

OMNETICS PART #	MIN	"A" MAX
A97006-101	.027 [.69]	.033 [.84]
A97006-102	.059 [1.50]	.065 [1.65]
A97006-103	.090 [2.29]	.096 [2.44]

DIMENSIONS IN [] ARE IN MILLIMETERS AND ARE FOR REFERENCE ONLY

LATCHING REAR PANEL MOUNT HARDWARE

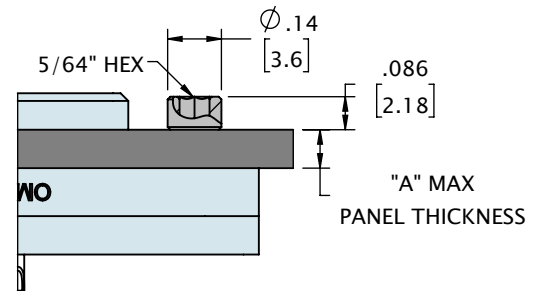
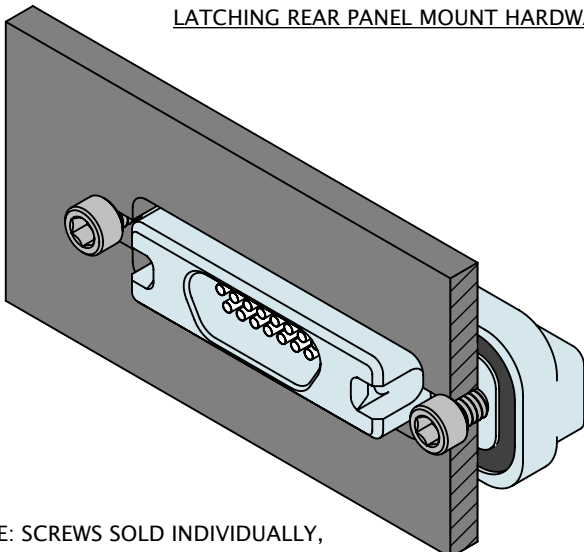

NOTE: SCREWS SOLD INDIVIDUALLY, ORDER 2 PER CONNECTOR

OMNETICS PART #	MIN	"A" MAX
D6292-156	.010 [.25]	.045 [1.14]
D6292-187	.045 [1.14]	.094 [2.39]

DIMENSIONS IN [] ARE IN MILLIMETERS AND ARE FOR REFERENCE ONLY

FRONT PANEL MOUNT CUTOUT

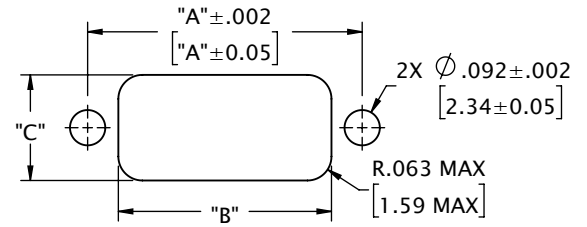
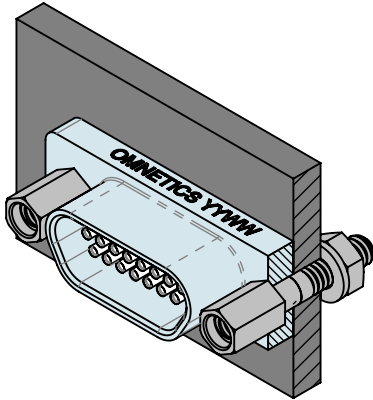

CONTACTS	ROWS	"A"	"B"	"C"
9	2	.565 [14.35]	.405 [10.29]	.275 [6.99]
15	2	.715 [18.16]	.555 [14.10]	.275 [6.99]
21	2	.865 [21.97]	.705 [17.91]	.275 [6.99]
25	2	.965 [24.51]	.805 [20.45]	.275 [6.99]
31	2	1.115 [28.32]	.955 [24.26]	.275 [6.99]
37	2	1.265 [32.13]	1.105 [28.07]	.275 [6.99]
51	2	1.615 [41.02]	1.455 [36.96]	.275 [6.99]
51	3	1.215 [30.86]	1.055 [26.80]	.315 [8.00]

DIMENSIONS IN [] ARE IN MILLIMETERS AND ARE FOR REFERENCE ONLY

REAR PANEL MOUNT CUTOUT

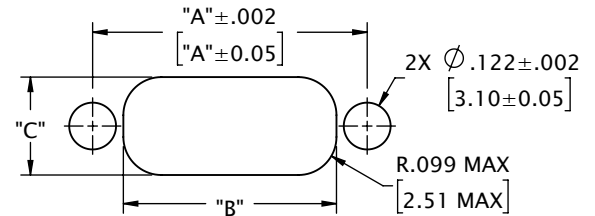
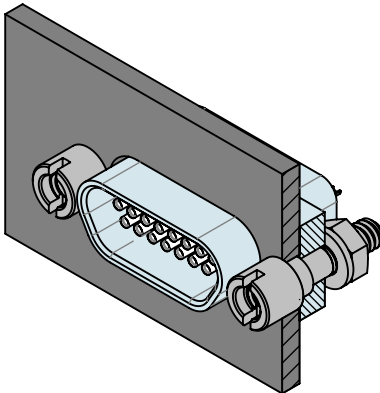

CONTACTS	ROWS	"A"	"B"	"C"
9	2	.565 [14.35]	.405 [10.29]	.255 [6.48]
15	2	.715 [18.16]	.555 [14.10]	.255 [6.48]
21	2	.865 [21.97]	.705 [17.91]	.255 [6.48]
25	2	.965 [24.51]	.805 [20.45]	.255 [6.48]
31	2	1.115 [28.32]	.955 [24.26]	.255 [6.48]
37	2	1.265 [32.13]	1.105 [28.07]	.255 [6.48]
51	2	1.615 [41.02]	1.455 [36.96]	.255 [6.48]
51	3	1.215 [30.86]	1.055 [26.80]	.298 [7.57]

DIMENSIONS IN [] ARE IN MILLIMETERS AND ARE FOR REFERENCE ONLY

LATCHING REAR PANEL MOUNT CUTOUT

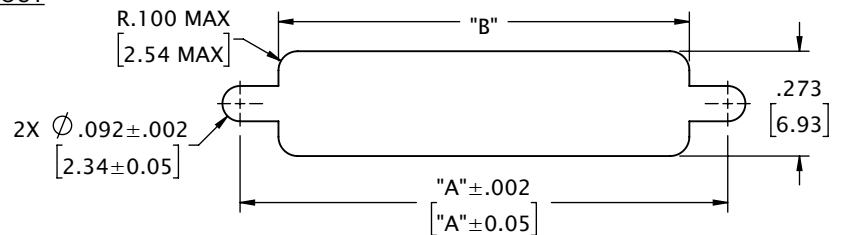
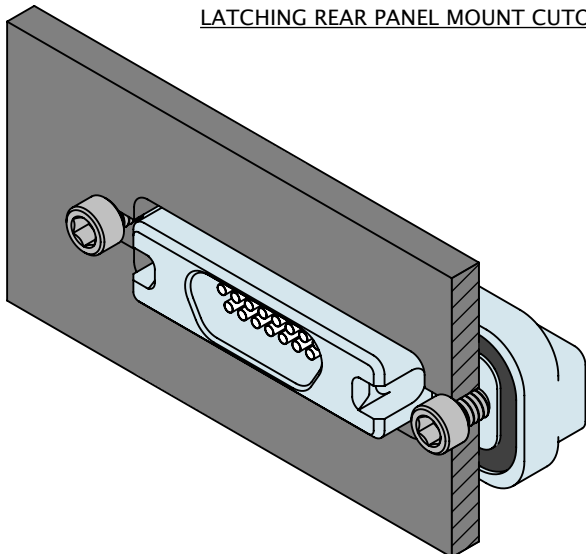

CONTACTS	ROWS	"A"	"B"
9	2	1.120 [28.45]	.920 [23.37]
15	2	1.270 [32.26]	1.070 [27.18]
21	2	1.420 [36.07]	1.220 [30.99]
25	2	1.520 [38.61]	1.320 [33.53]
31	2	1.670 [42.42]	1.470 [37.34]
37	2	1.820 [46.23]	1.620 [41.15]
51	2	2.170 [55.12]	1.970 [50.04]

DIMENSIONS IN [] ARE IN MILLIMETERS AND ARE FOR REFERENCE ONLY

HARDWARE & MISC

MICRO-D BACKSHELL
45 DEGREE ROUND ENTRY

OMNETICS PART #:
A97000-XXX

OPTION CODE:
BS1

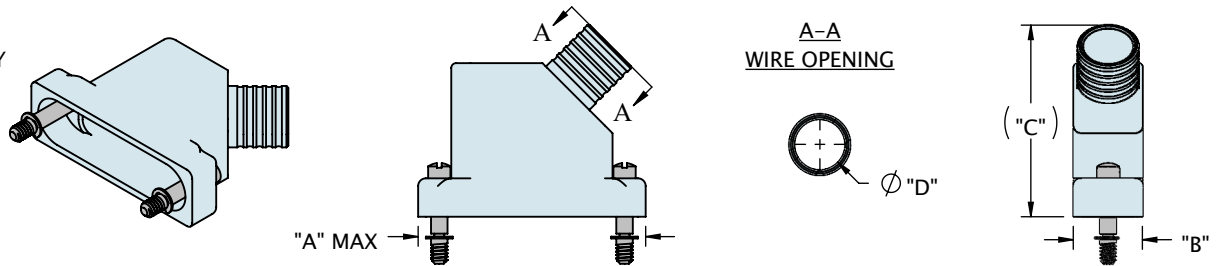

CONTACTS	ROWS	"A"	"B"	"C"	"D"
009	2	.785 [19.94]	.340 [8.64]	.848 [21.54]	.160 [4.06]
015	2	.935 [23.75]	.340 [8.64]	.898 [22.81]	.190 [4.83]
021	2	1.085 [27.56]	.340 [8.64]	.948 [24.08]	.220 [5.59]
025	2	1.185 [30.10]	.360 [9.14]	.998 [25.35]	.260 [6.60]
031	2	1.335 [33.91]	.360 [9.14]	1.038 [26.37]	.275 [6.99]
037	2	1.485 [37.72]	.360 [9.14]	1.078 [27.38]	.285 [7.24]
051	2	1.835 [46.61]	.413 [10.49]	1.078 [27.38]	.350 [8.89]
051	3	1.435 [36.45]	.413 [10.49]	1.160 [29.46]	.350 [8.89]
069	3	1.735 [44.07]	.473 [12.01]	1.160 [29.46]	.410 [10.41]

DIMENSIONS IN [] ARE IN MILLIMETERS AND ARE FOR REFERENCE ONLY

MICRO-D BACKSHELL
STRAIGHT OVAL ENTRY

OMNETICS PART #:
A97001-XXX

OPTION CODE:
BS2

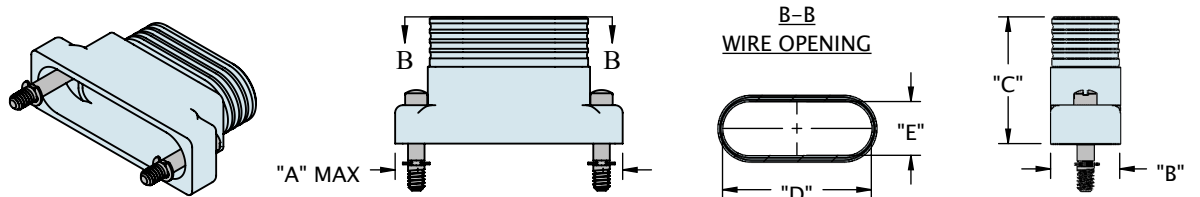

CONTACTS	ROWS	"A"	"B"	"C"	"D"	"E"
009	2	.785 [19.94]	.340 [8.64]	.66 [16.8]	.375 [9.53]	.280 [7.11]
015	2	.935 [23.75]	.340 [8.64]	.66 [16.8]	.525 [13.34]	.280 [7.11]
021	2	1.085 [27.56]	.340 [8.64]	.66 [16.8]	.675 [17.15]	.280 [7.11]
025	2	1.185 [30.10]	.360 [9.14]	.66 [16.8]	.775 [19.69]	.280 [7.11]
031	2	1.335 [33.91]	.360 [9.14]	.66 [16.8]	.925 [23.50]	.280 [7.11]
037	2	1.485 [37.72]	.360 [9.14]	.66 [16.8]	1.075 [27.31]	.280 [7.11]
051	2	1.835 [46.61]	.360 [9.14]	.66 [16.8]	1.425 [36.20]	.280 [7.11]
051	3	1.435 [36.45]	.380 [9.65]	.88 [22.4]	1.025 [26.04]	.320 [8.13]
069	3	1.735 [44.07]	.380 [9.65]	.88 [22.4]	1.325 [33.66]	.320 [8.13]
100	4	2.170 [55.12]	.423 [10.74]	.88 [22.4]	1.480 [37.59]	.363 [9.22]

DIMENSIONS IN [] ARE IN MILLIMETERS AND ARE FOR REFERENCE ONLY

MICRO-D BACKSHELL
90 DEGREE OVAL ENTRY

OMNETICS PART #:
A97002-XXX

OPTION CODE:
BS3

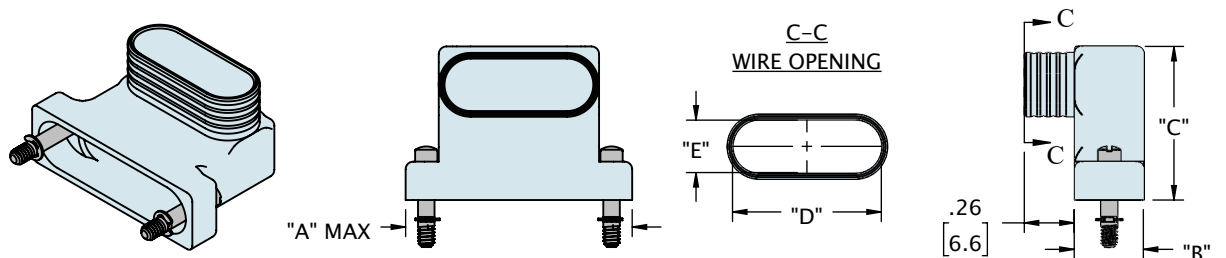

CONTACTS	ROWS	"A"	"B"	"C"	"D"	"E"
009	2	.785 [19.94]	.340 [8.64]	.80 [20.3]	.375 [9.53]	.273 [6.93]
015	2	.935 [23.75]	.340 [8.64]	.80 [20.3]	.525 [13.34]	.273 [6.93]
021	2	1.085 [27.56]	.340 [8.64]	.80 [20.3]	.675 [17.15]	.273 [6.93]
025	2	1.185 [30.10]	.360 [9.14]	.80 [20.3]	.775 [19.69]	.273 [6.93]
031	2	1.335 [33.91]	.360 [9.14]	.80 [20.3]	.925 [23.50]	.273 [6.93]
037	2	1.485 [37.72]	.360 [9.14]	.80 [20.3]	1.075 [27.31]	.273 [6.93]
051	2	1.835 [46.61]	.360 [9.14]	.80 [20.3]	1.425 [36.20]	.273 [6.93]
051	3	1.435 [36.45]	.400 [10.16]	1.00 [25.4]	1.025 [26.04]	.313 [7.95]
069	3	1.735 [44.07]	.400 [10.16]	1.00 [25.4]	1.325 [33.66]	.313 [7.95]

DIMENSIONS IN [] ARE IN MILLIMETERS AND ARE FOR REFERENCE ONLY

**MICRO-D BACKSHELL
45 DEGREE ELLIPTICAL ENTRY**

OMNETICS PART #:
A97003-XXX

OPTION CODE:
BS4

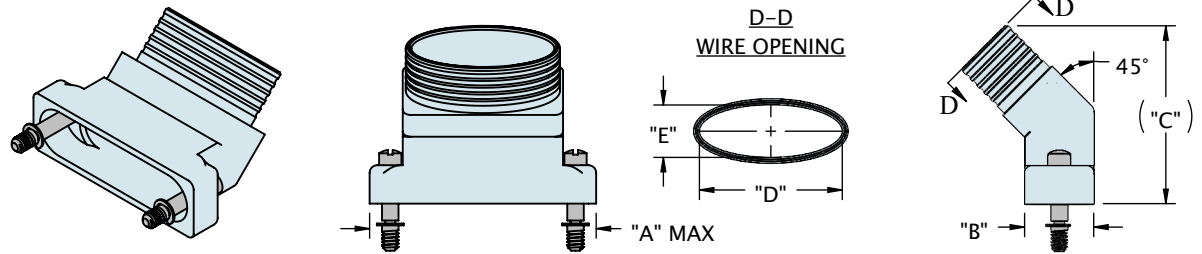

CONTACTS	ROWS	"A"	"B"	"C"	"D"	"E"
009	2	.780 [19.81]	.340 [8.64]	.834 [21.18]	.344 [8.74]	.273 [6.93]
015	2	.930 [23.62]	.340 [8.64]	.859 [21.82]	.494 [12.55]	.273 [6.93]
021	2	1.080 [27.43]	.340 [8.64]	.884 [22.45]	.644 [16.36]	.273 [6.93]
025	2	1.180 [29.97]	.360 [9.14]	.926 [23.52]	.744 [18.90]	.273 [6.93]
031	2	1.330 [33.78]	.360 [9.14]	.946 [24.03]	.894 [22.71]	.273 [6.93]
037	2	1.480 [37.59]	.360 [9.14]	.986 [25.04]	1.044 [26.52]	.273 [6.93]
051	2	1.830 [46.48]	.360 [9.14]	1.043 [26.49]	1.394 [35.41]	.273 [6.93]
051	3	1.430 [36.32]	.400 [10.16]	1.041 [26.44]	.994 [25.25]	.313 [7.95]
069	3	1.730 [43.94]	.400 [10.16]	1.048 [26.62]	1.294 [32.87]	.313 [7.95]

DIMENSIONS IN [] ARE IN MILLIMETERS AND ARE FOR REFERENCE ONLY

**MICRO-D BACKSHELL SPLIT
STRAIGHT ELLIPTICAL ENTRY**

OMNETICS PART #:
A97004-XXX

OPTION CODE:
BS5

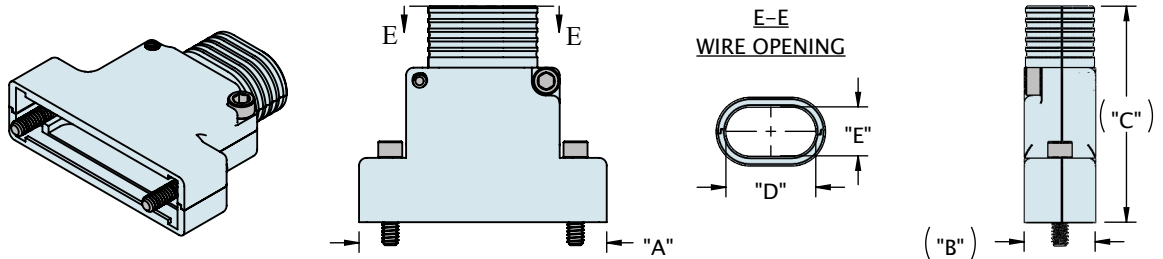

CONTACTS	ROWS	"A"	"B"	"C"	"D"	"E"
015	2	1.040 [26.42]	.370 [9.40]	1.075 [27.31]	.175 [4.45]	.255 [6.48]
021	2	1.190 [30.23]	.370 [9.40]	1.075 [27.31]	.368 [9.35]	.255 [6.48]
025	2	1.290 [32.77]	.370 [9.40]	1.125 [28.58]	.468 [11.89]	.255 [6.48]
031	2	1.440 [36.58]	.370 [9.40]	1.165 [29.59]	.618 [15.70]	.255 [6.48]
037	2	1.590 [40.39]	.370 [9.40]	1.205 [30.61]	.768 [19.51]	.255 [6.48]
051	2	1.940 [49.28]	.370 [9.40]	1.285 [32.64]	1.118 [28.40]	.255 [6.48]
051	3	1.540 [39.12]	.410 [10.41]	1.285 [32.64]	.718 [18.24]	.295 [7.49]
069	3	1.840 [46.74]	.410 [10.41]	1.600 [40.64]	1.018 [25.86]	.295 [7.49]
100	4	2.275 [57.79]	.453 [11.51]	1.351 [34.32]	1.238 [31.45]	.338 [8.59]

DIMENSIONS IN [] ARE IN MILLIMETERS AND ARE FOR REFERENCE ONLY

**MICRO-D BACKSHELL SPLIT
45 DEGREE ROUND ENTRY**

OMNETICS PART #:
A97005-XXX

OPTION CODE:
BS6

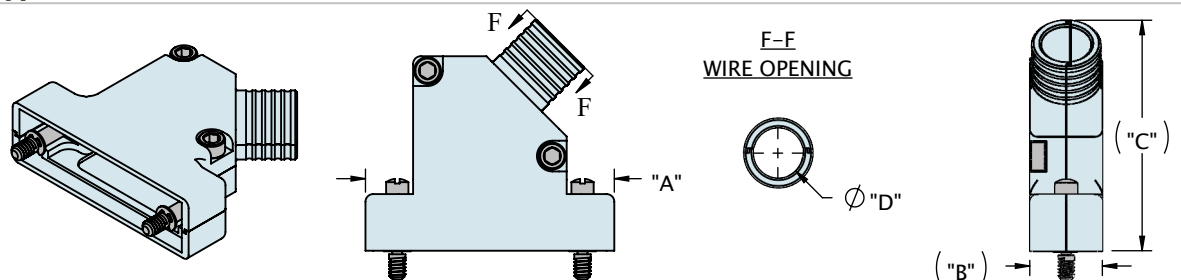

CONTACTS	ROWS	"A"	"B"	"C"	"D"
009	2	.896 [22.76]	.38 [9.7]	1.050 [26.67]	.160 [4.06]
015	2	1.046 [26.57]	.38 [9.7]	1.100 [27.94]	.190 [4.83]
021	2	1.196 [30.38]	.38 [9.7]	1.150 [29.21]	.220 [5.59]
025	2	1.296 [32.92]	.38 [9.7]	1.200 [30.48]	.260 [6.60]
031	2	1.446 [36.73]	.38 [9.7]	1.240 [31.50]	.275 [6.99]
037	2	1.596 [40.54]	.40 [10.2]	1.280 [32.51]	.285 [7.24]
051	2	1.946 [49.43]	.46 [11.7]	1.280 [32.51]	.350 [8.89]
051	3	1.546 [39.27]	.46 [11.7]	1.362 [34.59]	.350 [8.89]
100	4	2.281 [57.94]	.60 [15.2]	1.425 [36.20]	.490 [12.45]

DIMENSIONS IN [] ARE IN MILLIMETERS AND ARE FOR REFERENCE ONLY