

# MATERIALS & SPECIFICATIONS

PART NO.	A29400-031	REV	ECO	DATE	APP
		N	102438	03-16-16	TLM

**HOUSING:**  
ALUMINUM 6061-T6, NICKEL  
PLATE PER SAE-AMS-2404

**INSULATOR:**  
LIQUID CRYSTAL POLYMER (LCP)  
PER ASTM D5138

**CONTACTS:**  
COPPER ALLOY PER MIL-DTL-  
32139, GOLD PLATED PER ASTM  
B488, (HARD GOLD) TYPE II  
CODE C, CLASS 1.27

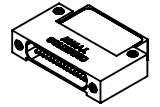
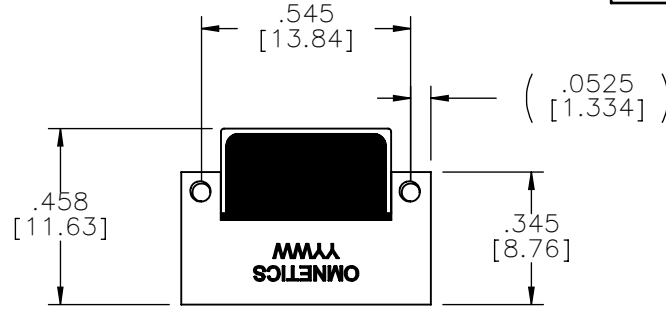

ACTUAL SIZE

**TERMINATION:**  
SOLDER COATED WITH SN63A  
PER J-STD-006

**CURRENT RATING:**  
1 AMP MAX PER MIL-DTL-32139

**CONTACT RESISTANCE:**  
71 MILLIOHM MAX (71mV DROP  
MAX) @ 1.0 AMPS PER MIL-  
DTL-32139

**PERFORMANCE:**  
PRODUCT FAMILY TESTED TO AND  
PASSED THE PERFORMANCE  
SPECIFICATIONS OF TABLE VIII OF  
MIL-DTL-32139

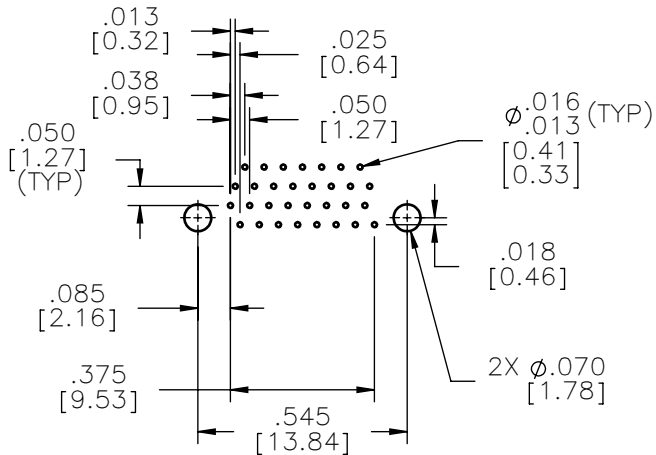
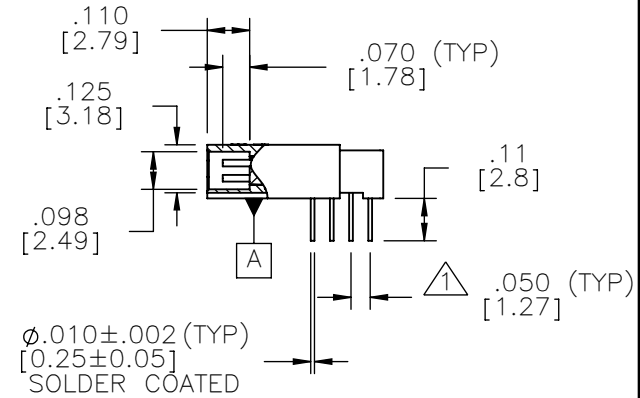
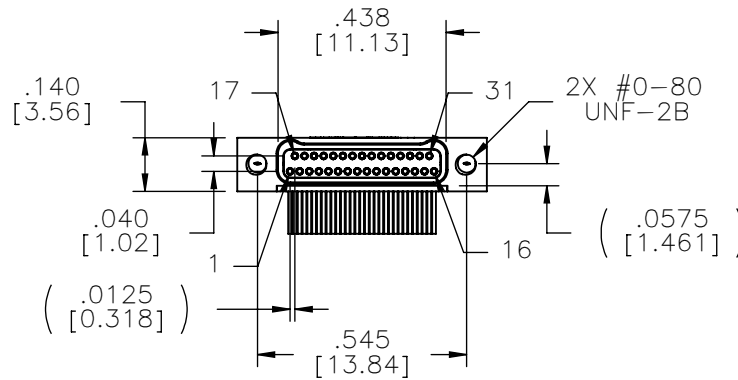

SUGGESTED HOLE PATTERN

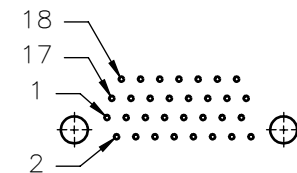
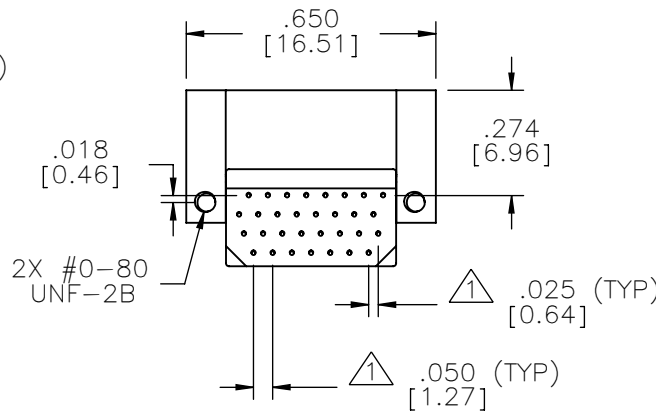

SUGGESTED HOLE PATTERN  
PIN OUT

△ TAIL DIMENSIONS APPLY AT PLANE A

**NOTE:**

DIMENSIONS IN [ ] ARE IN  
MILLIMETERS UNLESS  
OTHERWISE NOTED AND ARE  
FOR REFERENCE ONLY

MNSO CSNVA SLEW	THIRD ANGLE
	-TOLERANCES-
	UNLESS OTHERWISE NOTED
	DIMENSIONS IN INCHES
2 PL DEC ± .01	
3 PL DEC ± .005	
4 PL DEC ± .0005	
ANGLES ± 1°	

THIS DRAWING CONTAINS CONFIDENTIAL AND PROPRIETARY INFORMATION WHICH IS THE PROPERTY OF OMNETICS CONNECTOR CORP. THIS DOCUMENT MAY NOT, IN WHOLE OR IN PART, BE DUPLICATED, OR DISCLOSED FOR ANY PURPOSE, WITHOUT WRITTEN PERMISSION FROM OMNETICS CONNECTOR CORP.

DFTM. SKP	DATE
12-29-04	
CHK'D.	DATE
APP'D.	DATE

TITLE:  
(31) SOCKET FEMALE  
Bi-Lobe® CONNECTOR

**OMNETICS**  
CONNECTOR CORPORATION  
7260 COMMERCE CIRCLE EAST  
MINNEAPOLIS, MN 55432  
WWW.OMNETICS.COM

CAGE CODE	61873
DWG NO.	A29400-031
SHEET 1 OF 1	REV
SCALE: 2:1	N